

AIRCRAFT REFUELER (Civil, Military)

항공급유차 (민간, 군용)



ITEMS	5000 gal (19kl)		6500 gal (25kl)		5000 gal (19kl)
	Civil(민간)	Military(군용)	Civil(민간)	Military(군용)	Civil(민간)
Tank Capa.	5000gal + 3% Air space		6500gal + 3% Air space		8500gal + 3% Air space
Tank Mat'l	Al Alloy		←		←
Pump Capa'	600US GPM		←		←
Filter Flow Rate	600US GPM		←		←
Flow Meter	600US GPM	Under wing - 450US GPM Over wing - 150US GPM	600US GPM	Under wing - 450US GPM Over wing - 150US GPM	600US GPM
Under wing nozzle	100 mesh strainer and 45psi HECV		←		←
Over wing nozzle	-	100 mesh strainer	-	100 mesh strainer	-
Under wing pressure fuelling	600US Gal/min	450US Gal/min	600US Gal/min	450US Gal/min	600US Gal/min
Defuelling from Aircraft	200US Gal/min	150US Gal/min	200US Gal/min	150US Gal/min	200US Gal/min

PETROLEUM TANK FEATURE

당사 유류 탱크 특징

- ☑ 국내 최초 알루미늄 국산화 개발 (1993년)
The first succeed in domestically producing complete Aluminum Tank (1993)
- ☑ 국내 최초 육각탱크 및 BLS system 개발
The first development of Hexagon Tank and BLS system
- ☑ 국내 최초 횡용접 및 자동용접 실시
Conducting the domestic's first transverse welding and automatic welding
- ☑ 국내 최대 판매 (약 3000대 판매) - 자동차 제작사, 정유사, 운수회사
The most sales record in the domestic, (about 3000 units) - Car makers, Oil refinery companies, Transportation companies, etc
- ☑ 알루미늄 유류 탱크 국내 최대 수출 (대만, 베트남, 미국, 중동 등)
The most record of exporting Petroleum aluminum tank in Korea (Taiwan, Vietnam, USA, Middle east, etc)
- ☑ 수요자 요구에 따른 다양한 제품 제작
A variety of products subject to the Customers' Needs
- ☑ ISO9001, ISO14001 인증 획득
Obtaining certification of ISO9001 and ISO14001



DALIM SPECIAL VEHICLE CO.,LTD.

세계를 향하는 도전정신을 바탕으로 늘 성장하는
다임플라특장



다임플라특장주식회사
DA LIM DALIM SPECIAL VEHICLE CO.,LTD.

다임플라특장 경기도 화성시 서신면 제부로 722번길 36 T. 031)355-3329 F. 031)355-2128
221-32, Gwangpyeong-ri, Seosin-myeon, Hwasong-si, Gyeonggi-do, Korea

수송과 저장의 Global Partner!

DALIM PETROLEUM TANK LORRY, TRAILER

물류변화를 선도하는 특장업계의 선두주자
세계로 향하는 다임플라특장

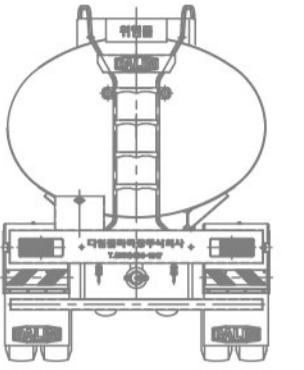

다임플라특장주식회사
DA LIM DALIM SPECIAL VEHICLE CO.,LTD.

TLS PETROLEUM TANK LORRY

상부 적재방식 유류 탱크로리



32KL TLS 외관 사면도

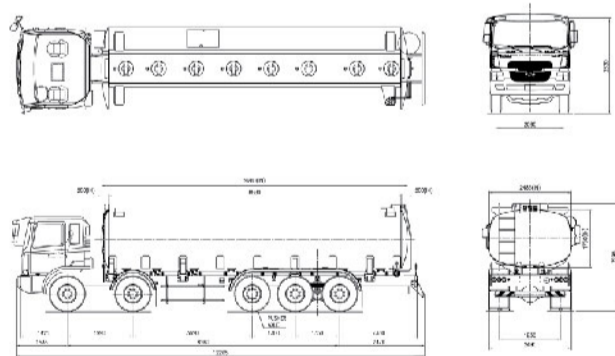

ITEMS	20KL	24KL	26KL	28KL	32KL
전장(mm) Overall Length	9630	9900	10315	10425	12265
전고(mm) Overall Height	3140	3325	3455	3480	3290
전폭(mm) Overall Width	2495	←	←	←	←
탱크형상 Tank Shape	육각형 Hexagonal	←	←	←	←
탱크재질 Tank Mat'l	알루미늄합금 Al Alloy	←	←	←	←
격실구분 Compartments	4000L x 5EA	4000L x 6EA	4000L x 6EA + 2000L x 1EA	4000L x 7EA	4000L x 8EA
부속품 Attachment Parts	펌프(Pump), 비상밸브(Emergency Valve), 스트레이너(Strainer), 안전밸브(Safety Valve) 사방 및 이방밸브(4way & 2way valve), 호스 및 호스박스(Hose & Hose box)				
적용사시 Chassis Grade	16Ton Grade (6x4)	20Ton Grade (1x3)	23.5Ton Grade (1x3)	23.5Ton Grade (1x3)	25Ton Grade (10x4)

BLS PETROLEUM TANK LORRY

하부 적재방식 유류 및 화공 탱크로리



32KL BLS 외관 사면도

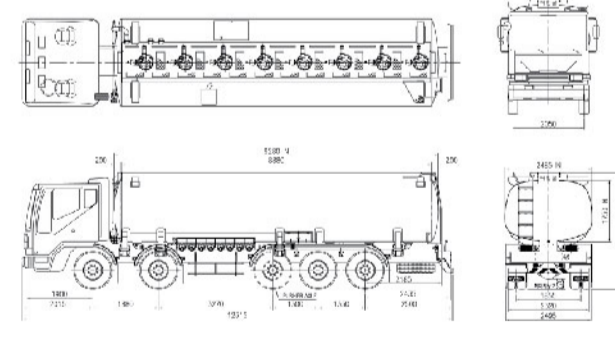

ITEMS	20KL	24KL	26KL	28KL	32KL
전장(mm) Overall Length	9585	9900	10315	10310	12220
전고(mm) Overall Height	3140	3325	3455	3480	3420
전폭(mm) Overall Width	2495	←	←	←	←
탱크형상 Tank Shape	육각형 Hexagonal	←	←	←	←
탱크재질 Tank Mat'l	알루미늄합금 Al Alloy	←	←	←	←
격실구분 Compartments	4000L x 5EA	4000L x 6EA	4000L x 6EA + 2000L x 1EA	4000L x 7EA	4000L x 8EA
부속품 Attachment Parts	비상밸브(Emergency Valve), 하부적재부품(Bottom loading Comp.), 증기회수부품(Vapor recovery Comp.), 과적재방지부품(Overfill detection and electronics)				
적용사시 Chassis Grade	16Ton Grade (6x4)	20Ton Grade (1x3)	23.5Ton Grade (1x3)	23.5Ton Grade (1x3)	25Ton Grade (10x4)

TLS PETROLEUM TANK TRAILER

상부 적재 방식 유류 탱크 트레일러

BLS PETROLEUM & CHEMICAL TANK TRAILER

하부 적재 방식 유류 및 화공 탱크 트레일러



32KL BLS 외관 사면도

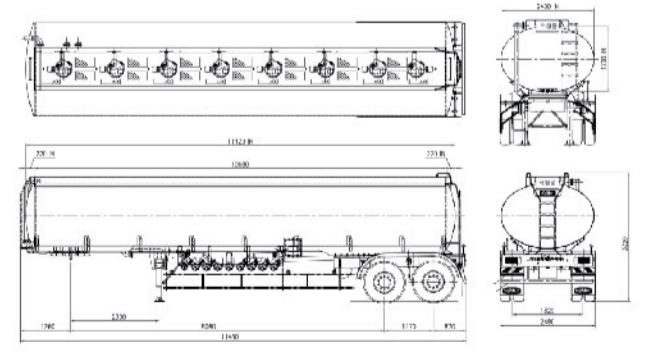

ITEMS	32KL BLS	32KL TLS	29KL TLS	24KL EG	28,8KL ASP
전장(mm) Overall Length	11540	11480	11050	10550	12475
전고(mm) Overall Height	3470	3320	3440	3230	3700
전폭(mm) Overall Width	2495	←	←	←	←
탱크형상 Tank Shape	타원형 Elliptical	←	←	←	원통형 Round
탱크재질 Tank Mat'l	알루미늄합금 Al Alloy	←	←	←	←
적재물질 Products	Heavy Petroleum (중질유)	Light Petroleum (경질유) Chemical(화공)	Heavy Petroleum (중질유)	Ethylene glycol (에틸렌 글리콜)	Asphalt (아스팔트)
격실구분 Compartments	4000L x 5EA	4000L x 6EA	4000L x 6EA + 2000L x 1EA	4000L x 7EA	4000L x 8EA
부속품 Attachment Parts	TLS Petroleum tank lorry와 동일	BLS Petroleum tank lorry와 동일	TLS Petroleum tank lorry와 동일	TLS Petroleum tank lorry와 동일	보온(Insulation) 외피(Outer Tank)
적용사시 Chassis Grade	Da Lim Trailer Chassis (Air Bag, AI wheel, ABS)				