

Technical Date (기술자료)

▶ 47KL LH2 Tank TRL 외관도

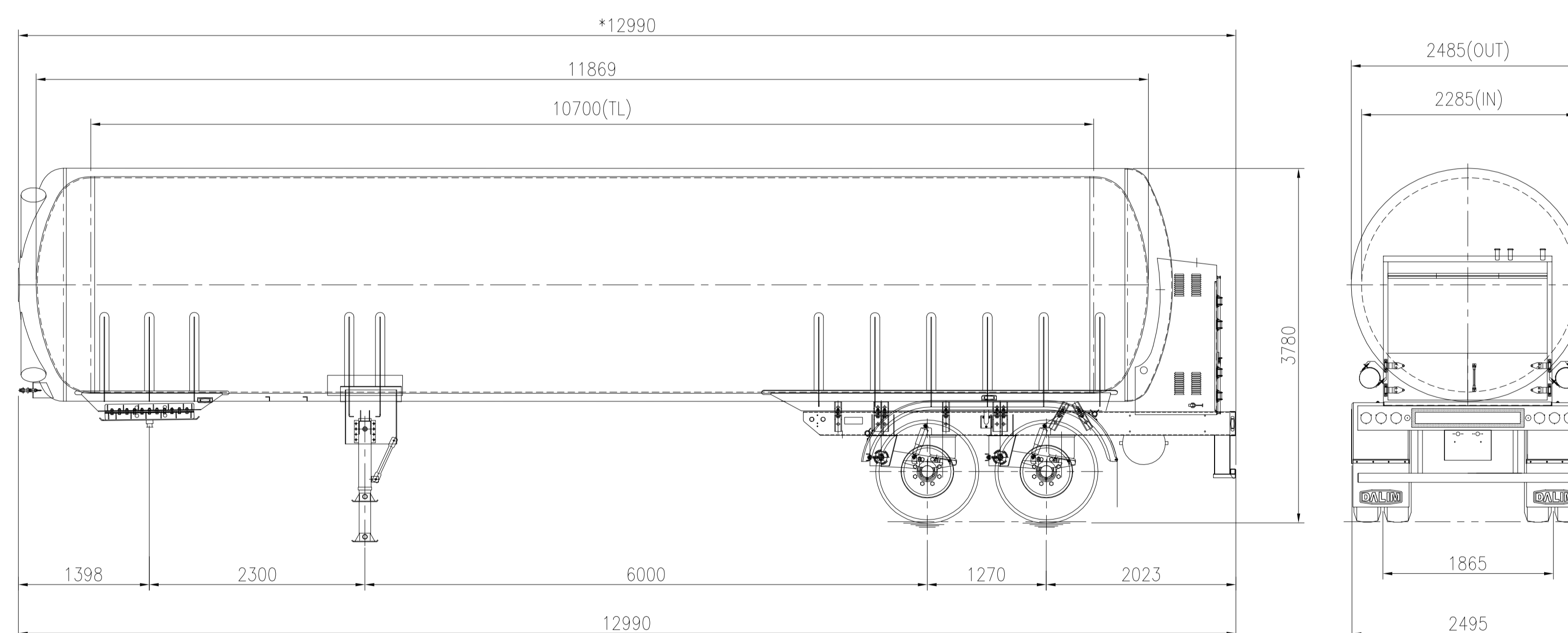

▶ 기술자료

Chassis(샤시)			Tank(탱크)		
Item(항목)	Specifications(제원)	Remarks(비고)	Item(항목)	Specifications(제원)	Remarks(비고)
OVERALL LENGTH(전장)	12,990mm		Volume(용량)	47,000L	
OVERALL WIDTH(전폭)	2,495mm		INNER DESIGN PRESSURE(내탱크 설계압력)	1.2MPa	
OVERALL HEIGHT(전고)	3,780mm		OUTER TANK DESIGNURE EXTERNAL PRESSER(외탱크 외부설계압력)	0.2MPa	
WHEEL BASE(축간거리)	8,300+1,270 = 9,570mm		INNER/OUTER TANK MAT'L(내/외탱크 재질)	STAINLESS STEEL	
CURB WEIGHT(공차 중량)	23,000kg		INSULATION(단열방식)	DOUBLE WALLET VACUUM INSULATION	
MAX.PAYLOAD(최대적재량)	3,000kg		DESIGN TEMPERATURE(설계온도)	-253 ~ +40 도	
GROSS BEHICLE WEIGHT(차량총중량)	26,000kg		VALVE TYPE(밸브 형식)	JACKET TYPE	
SPRING(스프링)	AIR SPRING(공기스프링)		PIPING(배관)	VACUUM INSULATION	
BRAKE(브레이크)	EBS(RSS, 전복방지장치)		SAFETY DEVICE(안전장치)	SVM(Surround View Monitor)	
TIRE,WHEEL	12R22.5, AL ALLOY		MONITORING SYSTEM(Web, APP 지원)	GPS, Tank Pressure & Level, Gas Detector	